

REINHOLD ENVIRONMENTAL Ltd.



**2018 NO_x-Combustion Round Table
& Expo Presentation**

February 19-20, 2018, in St. Louis, MO / Hosted by Dynegy

All presentations posted on this website are copyrighted by Reinhold Environmental, Ltd (RE). Any unauthorized downloading, attempts to modify or to incorporate into other presentations, link to other websites, or obtain copies for any other uses than the training of attendees to RE's Conferences is expressly prohibited, unless approved in writing by RE or the original presenter. RE does not assume any liability for the accuracy or contents of any materials contained in this library which were presented and/or created by persons who were not employees of RE.



Hydrated Lime Injection Upstream of the SCR to Mitigate SO₃

2018 NO_x RT
Mark Thomas & Associates
Consulting, LLC

SO₃ MITIGATION STRATEGIES

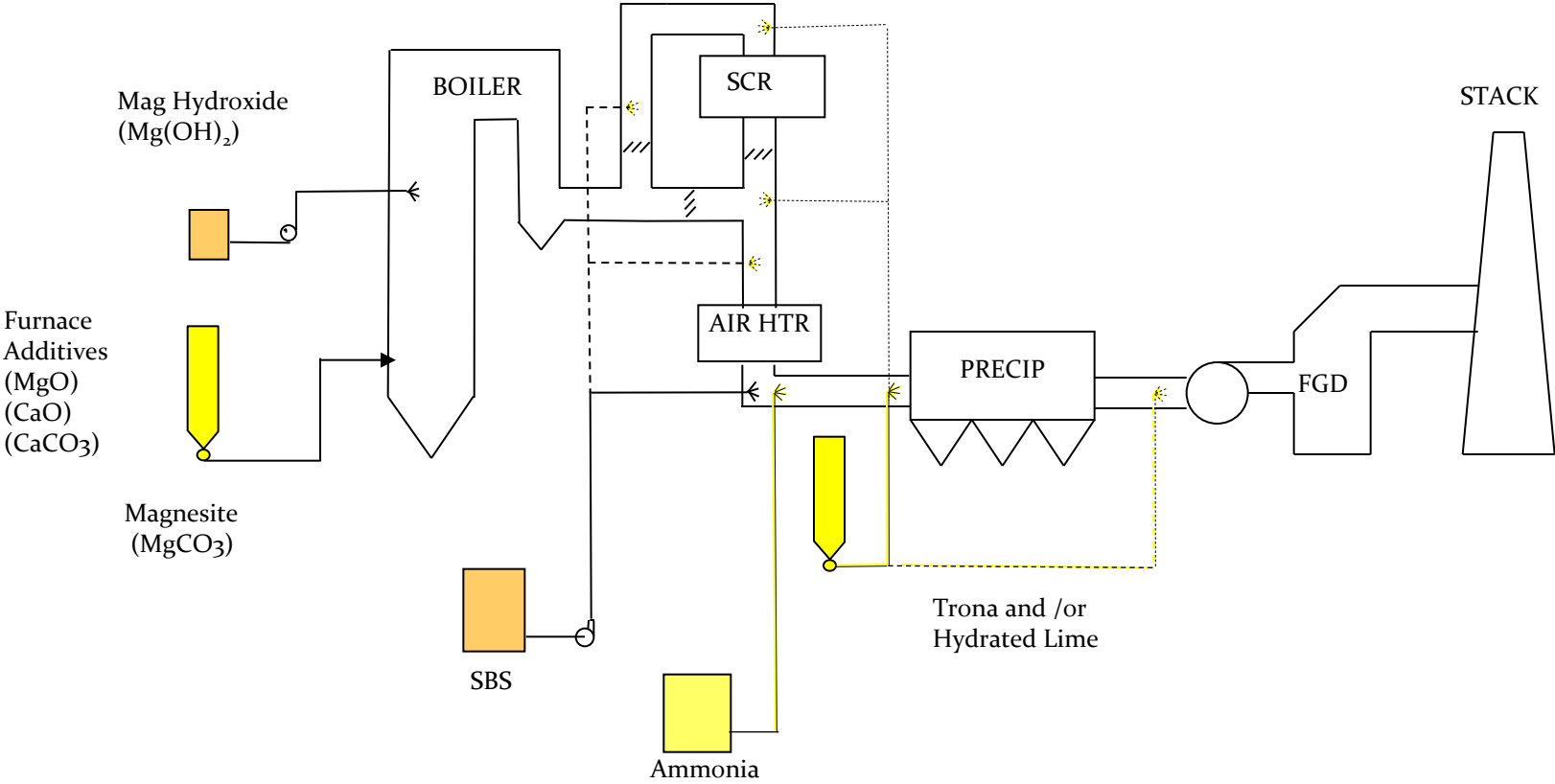

Pre-SCR Hydrated Lime DSI to Mitigate SO₃

- **WHY CONSIDER?**
 - Low Load/ Extended SCR & Unit Turndown
 - Need Pre-APH or Pre-ESP/FFDC DSI but have Physical Constraints for DSI installation
 - Possibly More Simple Installation
 - Possible Performance Improvements

- **FACTORS TO CONSIDER?**
 - What is Objective?
 - SCR Turndown/ MOT Reduction?
 - APH Pluggage Protection?
 - Improved Performance & Residence Time?
 - Other?
 - What is expected operational profile
 - Inject Only at Min Load or Continuously?
 - AH Protection?
 - Expected SCR NOx Removal Requirements?
 - What Potential Negative Impacts
 - Catalyst Blinding?
 - Pluggage/ Layout Potential
 - Other?

CATALYST IMPACTS DISCUSSION

Primary Concern for Catalyst Impacts is

- Submicron CaO
- High concentrations of CaO
- Primarily a concern for PRB coals
 - Fly Ash can contain 20-25% CaO

Pre-SCR DSI has not shown any negative Catalyst Impacts

- Hydrated Lime is $\text{Ca}(\text{OH})_2$ not CaO
- Particle size is significantly larger
- Concentration of $\text{Ca}(\text{OH})_2$ in ash is ~2%-8% which is in significantly lower than for PRB Coals

Catalyst Pluggage Concerns

- Physical Pluggage Mechanism
- Depends on existing ash pluggage situation
 - Ash Falls from excessive buildups especially at low load.
 - Buildups on Turning Vanes, etc
- Will require careful control of lime feed at low load

DESIGN CONSIDERATIONS

- SCR Design – Space Limitations
- Lime Dispersion Important
- Mixing Critical if Load Following / MOT is primary
 - Existing Static Mixing Devices for NH₃?
 - Distance to AIG & Catalyst
- % RMS not as strict as for SCR but depends on situation
- Can Use Existing Static Mixers if possible
- Lance Design and Location very important

EVALUATE POTENTIAL SCR & BOP IMPACTS AND BENEFITS

- Consider Testing
 - Single duct testing could prove concept
 - Test Location – Depends in Ppart on objective

CASE STUDY

- Zimmer Power Station
- Moscow, Ohio
- 1440 Mw Gross
- Worlds Only Nuclear to Coal Conversion
- In Service 1991 with Wet FGD
- SCR Added 2004

Zimmer DSI Systems History

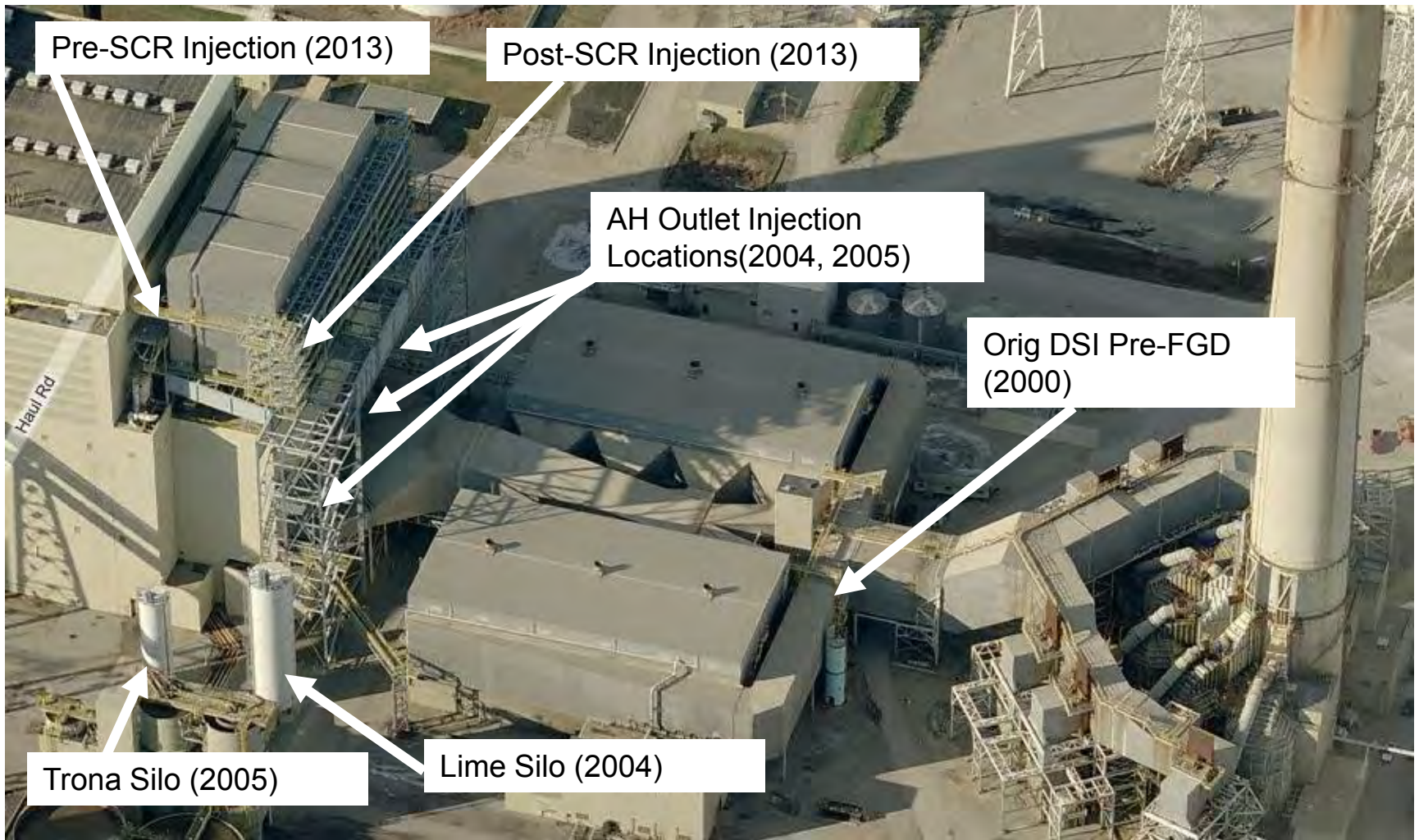

PRE-SCR INJECTION

- Initially Installed to resolve APH Pluggage Problem
- Location Selected for Simplicity
- Initially Injected Continuously Pre-SCR
- Added Post-SCR/ Pre APH Injection
 - Switched to Dual Injection
- Currently Inject Pre-SCR only at Low Load

Zimmer Power Station AQCS Config and Sorbent Injection Locations

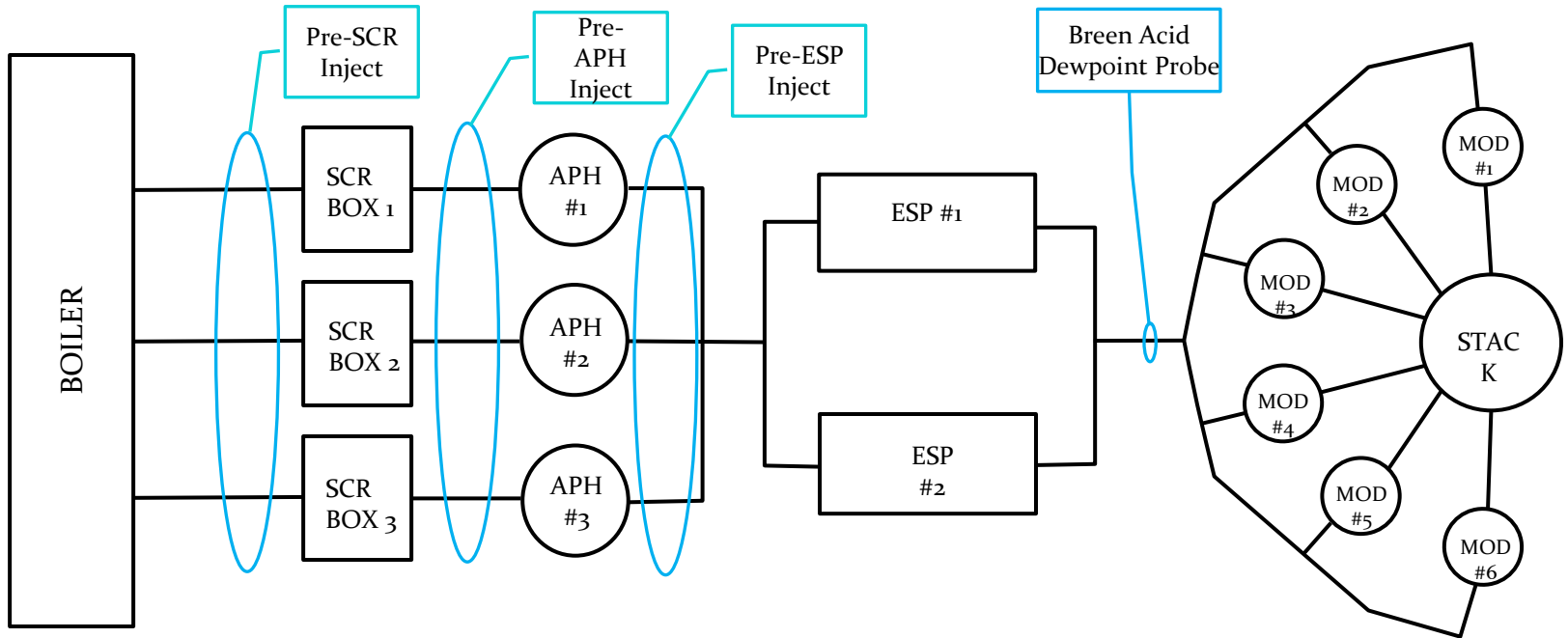

Zimmer SO₃ Mitigation Systems

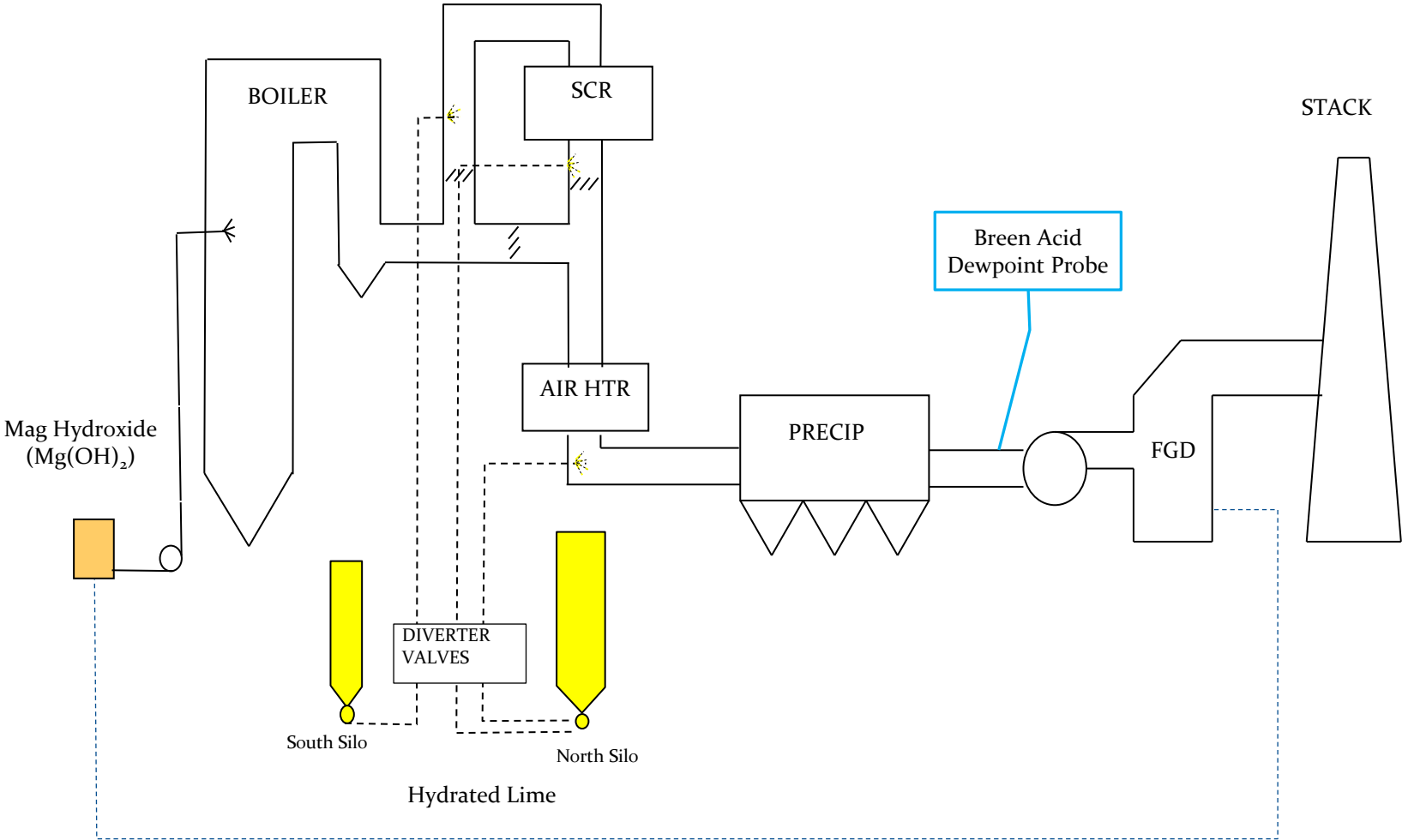

NH₃ INJECTION NOZZLE AND DELTA WING MIXERS (4 Per duct)



Diverter Valves



EFFECT ON SCR OPS

- Lowered Min Temps by >30F
 - Allows significant lower Min Load
 - Not require Low Load Gas Temp Mods
 - Based on Reducing SO₃ to ~5ppm @SCR Inlet
 - Currently Use Tiered DeNO_x @ Lower Loads
 - Can Likely Push to Lower Temps

CATALYST IMPACTS

- No Accelerated Catalyst Deactivation
- Slight Catalyst CaO Increase
- No Catalyst Pluggage
 - From Buildups or Ash/Lime Falls
- No Increased Catalyst Erosion
- No Deposits after 6 Month Outage w/o Layup Air heating thru Winter Season
- No Negative Impacts on Hg Oxidation

OTHER BOP EFFECTS AND FINDINGS

- Elimination of APH Fouling for 5 Years
- Permits More HR Benefit @ Low Load
 - Elim need for APH Air Side Bypass
 - Reduced Combust Air Pre-Heat >> Lower SCR In Temps
- Proportionally Less Sorbent Needed at Low Load due to lower SO₃ at Low Load
 - Case Specific
- HCl Capture more efficient w/ Pre SCR Injection
- SO₃ Capture more efficient w Post SCR/ Pre APH

SORBENT MIXING

- Sorbent Mixing Critical
 - More Important near MOT/ MIT
 - Need to good coverage to prevent localized ABS formation
- Similar Issues as NH_3 Mixing
 - Added Erosion & Buildup Potential
 - Practical Limit on Number of Lances

OTHER CONSIDERATIONS

- DSI System Redundancy
 - Silos, Feeders, Distribution Piping, Lances, Etc
- SCR Bypass Duct & Dampers Config & Ops
- Controls & Operating Procedures
- Econ Gas or Water Bypass for SCR Inlet Temp Control
 - Reduced Maintenance or Eliminate Need for
- Preheat Coil Operation
- Ash Sales (Chloride Limits, Calcium Limits)

SUMMARY & CONCLUSION

- So Far No Negatives
- Significant Unit Turndown Improvement
- Air Heater Fouling Elimination
- Additional Advancements Under Evaluation